

# EPC - FUSION BONDED EPOXY COATED CAST IRON HUBLESS BEND



COMPLY WITH EN877:2010 01

\*Availability upon request

## COATING CHARACTERISTIC

### Fittings:

Epoxy fittings inside and outside: Fusion bonded epoxy coating.

Coating Thickness: Min- 240µm

## 15° BEND

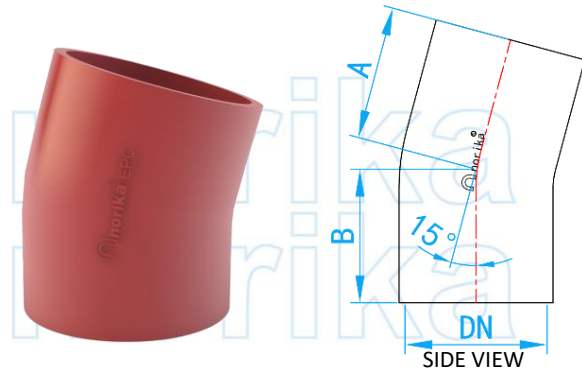

### DIMENSIONS

SKU	DN (mm)	A (mm)	B (mm)	WEIGHT (kg)
HUBEB15050	50	40	40	0.6
HUBEB15080	75	50	50	0.8
HUBEB15100	100	50	50	1.0
HUBEB15125	125*	60	60	1.7
HUBEB15150	150	65	65	2.5
HUBEB15200	200	80	80	4.6

## 30° BEND

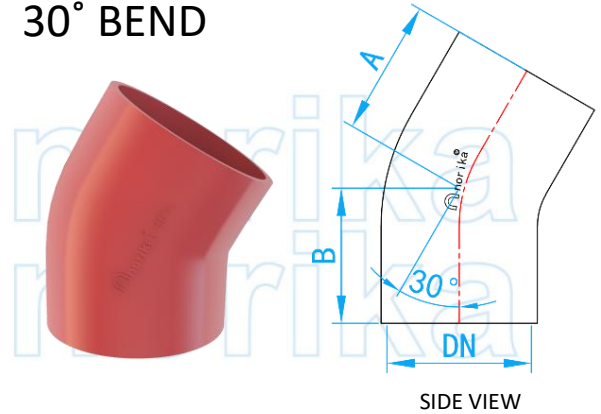

### DIMENSIONS

SKU	DN (mm)	A (mm)	B (mm)	WEIGHT (kg)
HUBEB30050	50	45	45	0.5
HUBEB30080	75	60	60	0.8
HUBEB30100	100	60	60	1.3
HUBEB30125	125*	70	70	2.0
HUBEB30150	150	80	80	3.0
HUBEB30200	200	95	95	5.4
HUBEB30250	250	110	110	9.7
HUBEB30300	300	130	130	15.5

## 45° BEND

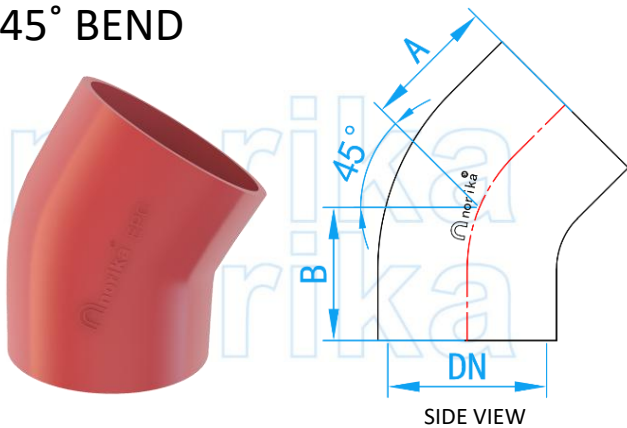

### DIMENSIONS

SKU	DN (mm)	A (mm)	B (mm)	WEIGHT (kg)
HUBEB45050	50	60	60	0.5
HUBEB45080	75	60	60	1.0
HUBEB45100	100	70	70	1.6
HUBEB45125	125*	80	80	2.3
HUBEB45150	150	90	90	3.0
HUBEB45200	200	110	110	6.2
HUBEB45250	250	130	130	13.2
HUBEB45300	300	155	155	17.3

## 88° BEND

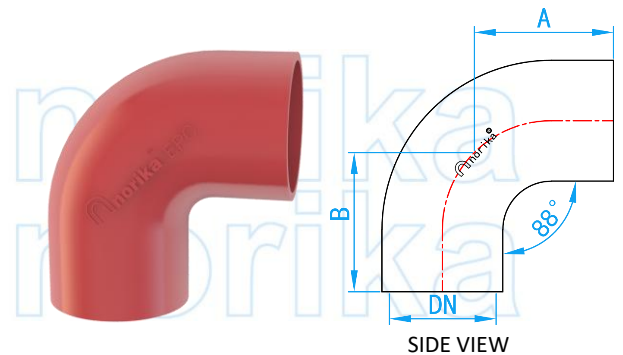

### DIMENSIONS

SKU	DN (mm)	A (mm)	B (mm)	WEIGHT (kg)
HUBEB90050	50	75	75	0.7
HUBEB90080	75	95	95	1.4
HUBEB90100	100	110	110	2.1
HUBEB90125	125*	125	125	3.2
HUBEB90150	150	145	145	4.9
HUBEB90200	200	180	180	8.8
HUBEB90250	250	225	225	17.9
HUBEB90300	300	260	260	28.0

**Notes:** The tolerance for Weight is  $\pm 10\%$ .